

TORQSENSE®

SGR510/511/512 Series Analog Rotary Torque Transducer

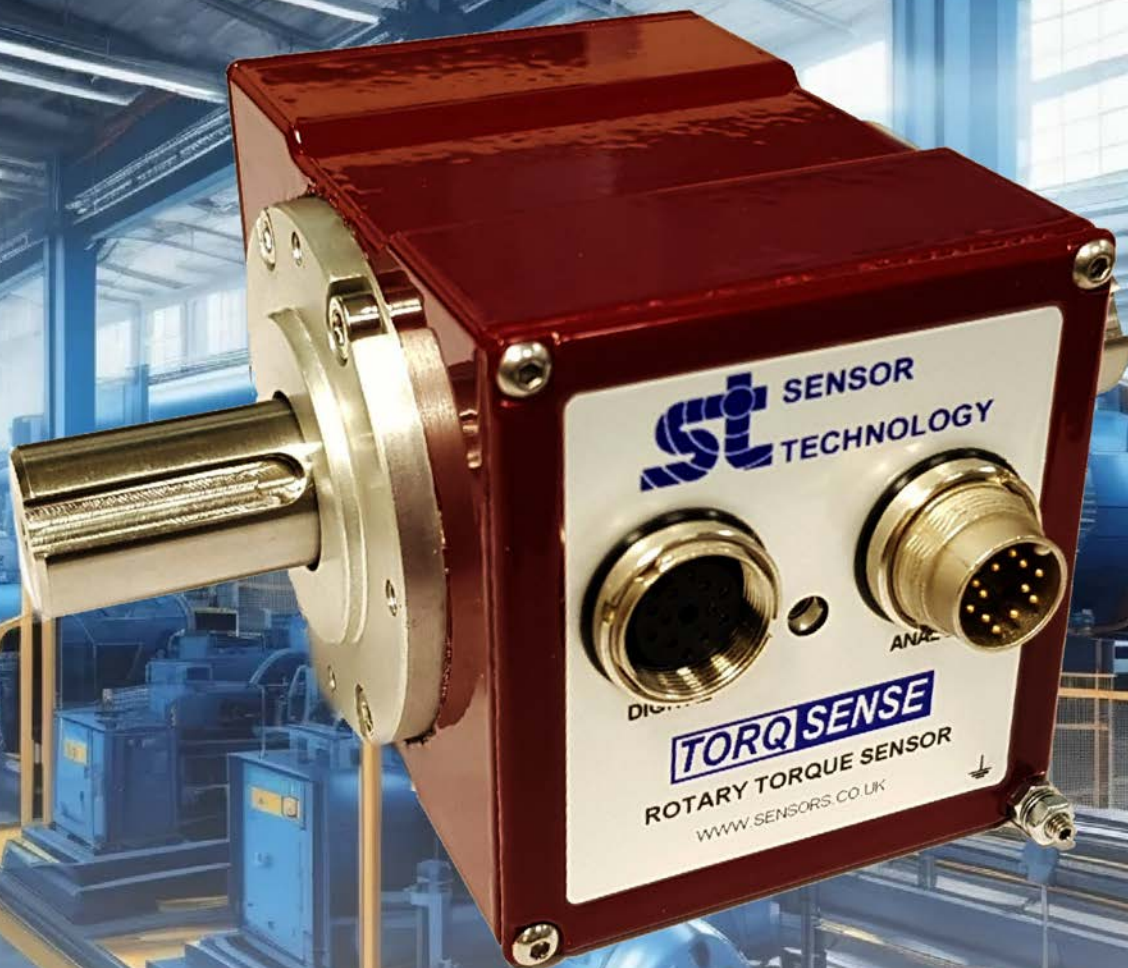

 **SENSOR
TECHNOLOGY**

Tel: +44 (0)1869 238400
Email: info@sensors.co.uk
Web: www.sensors.co.uk

SGR510/511/512 series Torque Transducer

Torqsense Digital rotary strain gauge series (SGR) Transducers use non contact technology eliminating the need for noisy slip rings. They are suitable for torque measuring, testing, feedback control of drive mechanisms and process control applications.

The SGR series transducers use modern strain gauge signal conditioning techniques to provide a high bandwidth low cost torque measuring solution with high overrange and overload capabilities.

Benefits & Features

- Transducers from 175mNm to 13000 Nm.
- Minimal side and end load errors
- Low linearity deviation of $\pm 0.05\%$ FSD
- Low hysteresis error of $\pm 0.05\%$ FSD
- Zero variation in torque signal with rotation (cyclic variation)
- Non contact signal transmission, no slip rings to wear out
- High digital sample rate of 4000 samples per second
- Speed measurement / Angle / Power computation
- Wide power supply range 12-32 VDC

Technology

The SGR series torque transducers use a full four element strain gauge bridge to measure the torsion present on a shaft. The full bridge helps to diminish errors from any off-axis forces that are sometimes unintentionally applied to the transducer in some test setups. The full bridge also increases the sensitivity and the temperature performance of strain measurement.

A rotor mounted ultra-miniature microcontroller measures the strain gauge bridge and transfers the information back to the stator digitally eliminating any noise pickup usually associated with slip ring and other analog methods of transferring torque data from rotor to stator. External noise pickup into the gauge wiring is virtually eliminated due to the short distance between the strain gauge elements and the rotors measuring circuits.

A multipoint calibration method reduces any linearity errors within the sensor. A large functional overrange capability allows the peaks of a torque signal to be captured more faithfully without any clipping when operating the sensor close to its full scale rating.

All this combined with a mechanical overload capability of over 400% make the SGR series torque sensors a very robust and accurate torque measuring solution.

TorqSense SGR510/511/512 transducers offer:

- **SGR510** - Torque measurement only
- **SGR511** - Torque, speed & power measurement (60 pulses per revolution encoder)
- **SGR512** - Torque, speed/angle & power measurement (360 pulses per revolution incremental encoder)
- Fixed voltage or current analog outputs for interfacing with analog instrumentation. 3 channels are available, channel assignment based on model.
- BIT Self-diagnostics - Diagnostic system checks internal systems and operational conditions for faults, and monitors torque, speed and temperature for overscale conditions.
- Transducer status LED and simple "Sensor status" output pin, provide transducer health feedback.
- Sensors to monitor shaft temperature for better compensation and accuracy.

Examples of reading/collecting analog data

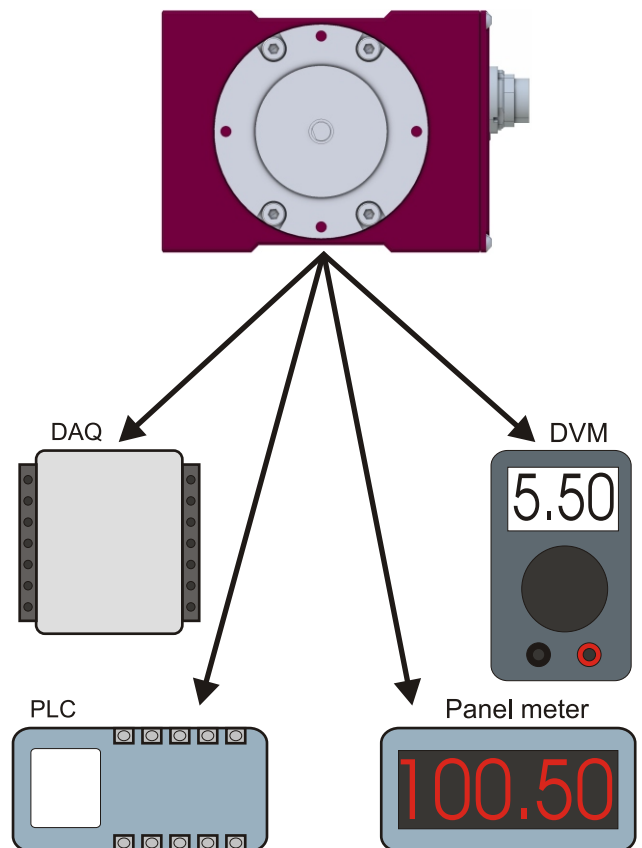

SGR510/511/512 Torque Transducers - Data Specification

Parameter	Condition	Data						Units
SGR510/511/512 Torque measurement system								
Measurement method		Full bridge strain gauge						
Torque range	<i>(Notes 1 & 2)</i>	0 – 1	0 – 1.1 to 0 - 20	0 – 21 to 0 - 100	0 – 101 to 0 - 500	0 - 501 to 0 - 2000	0 – 2001 to 0 - 13000	Nm
		<i>[0 - 10]</i>	<i>[0 - 11 to 0 - 200]</i>	<i>[0 - 201 to 0 - 1000]</i>	<i>[0 - 1001 to 0 - 5000]</i>	<i>[0 - 5001 to 0 - 20000]</i>	<i>[0 - 20001 to 0 - 175000]</i>	<i>[lbf·in]</i>
Shaft size (diameter)		6	12	20	30	50	75	mm
Specifications								
Combined non-linearity and hysteresis		±0.1						%FS
Resolution		0.01						%FS
Repeatability		0.05						%FS
Accuracy	20°C, SM <i>(Note 4)</i>	±0.2						%FS
3dB Bandwidth	<i>(Notes 5&6)</i>	250 (default ave. = 16)						Hz
Analog output								
Output voltages (Torque/Speed/Power)		Options available: ±1 / ±5 / ±10 / Unipolar (SGR510 Series default setting is ±5Vdc)						Vdc
Load impedance		Maximum 1						KΩ
Output currents (Torque/Speed/Power)		Options available: 4-20 / 0-20 / 12±8						mA
4-20mA Loop resistance		Should not exceed 400						Ω
Rotation speed/angle of rotation measurement system								
Measurement method		Opto switch through slotted disc						
Direct output signal		Pulse output direct from opto switch (TTL, 5V square wave)						
Accuracy		Speed: ±1rpm up to 30,000rpm			Angle: ±1° (360 encoder only)			
Rotational speed (max)	<i>(Note 3)</i>	30,000	20,000	15,000	12,000	9,000	6,000	RPM
Digital Processing Techniques Processing modes run simultaneously and can be applied to either analog channel or accessed individually via a digital connection.	Based on a standard 60-line grating. <i>(Note 11)</i>	Processing Method		Update rate for analog and digital outputs				
		Mode 1 (Slow Method) Frequency Count		1				Hz
		Mode 2 (Fast Method) Period Count		0 RPM	1			Hz
				> 0 RPM	$\frac{\text{RPM}}{\text{RPM}} \left \frac{\text{RPM}}{1000} \right $			
Temperature								
Temperature accuracy		±1						°C
Reference temperature T _{RT}		20						°C
Compensated range, ΔT _O		0 to +90						°C
Usable range, ΔT _S		-40 to +90						°C
Temperature		Coefficient of zero 0.002						%
Temperature		Coefficient of span 0.01						%
Power supply								
Nominal voltage, V _S		12 to 32 (max)						V
Current consumption, I _S		250 (max) @ 12 VDC						mA
Power consumption, W _S		3						W
Allowed residual ripple of supply voltage, V _{ripple}		500 (above nominal supply voltage)						mVp-p
Electromagnetic compatibility								
EMC compatibility		EN 61326:2006						

** For notes, please see glossary page*

SGR510/511/512 Torque Transducers

Dimensions (1Nm to 100Nm)

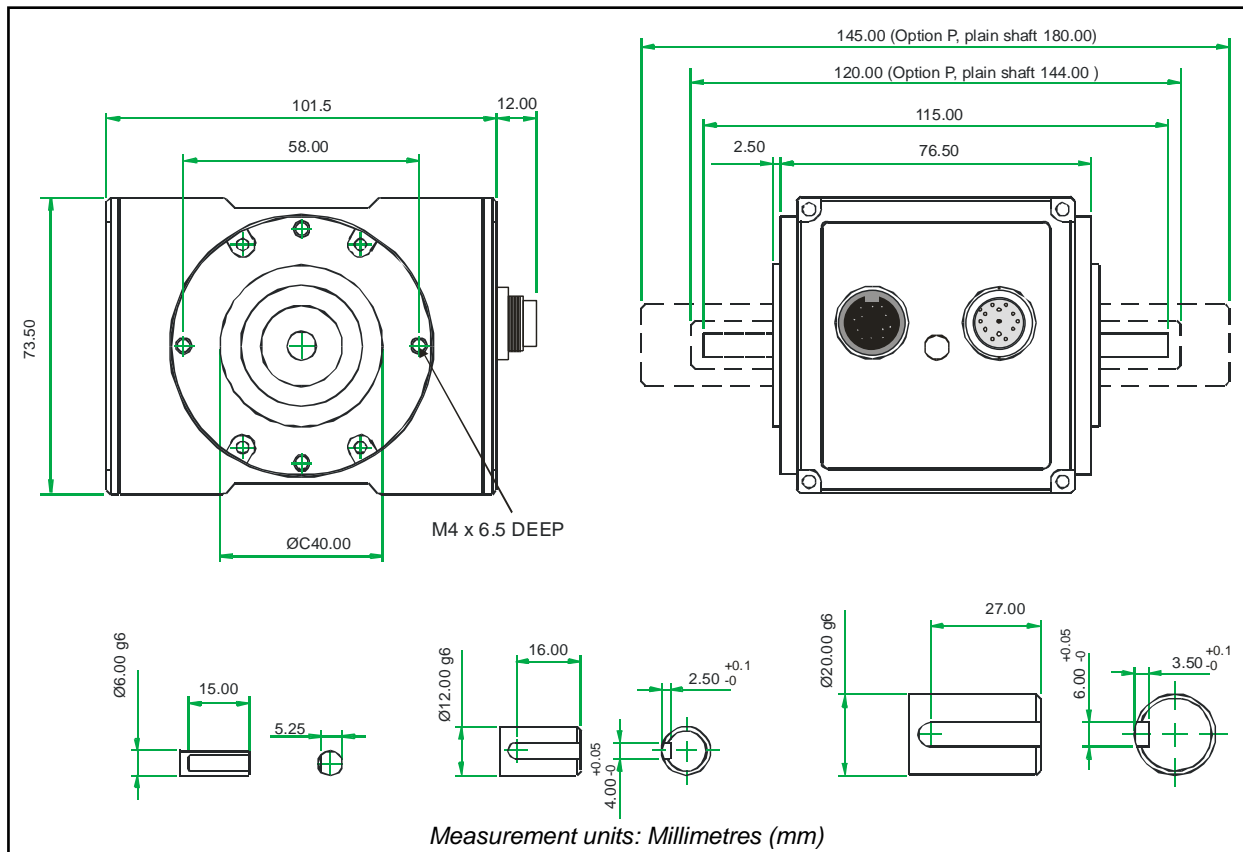

Parameter	Data														Units
Mechanical Properties															
Torque (Max)	0.225	0.6	1	2.5	3.5	6	8.5	13	17.5	20	30	55	85	100	Nm
Shaft Code	CD	CE	CF	DA	DF	DB	DC	DG	DD	DE	EB	EC	ED	EE	
Standard Shaft Type	Plain	Plain	Flat	Keyed											
Shaft Size (Diameter)	6			12						20					mm
Torsional Stiffness	0.23	0.23	0.23	1.28	1.3	1.32	1.6	1.7	1.8	1.9	4.1	6.4	8.1	9.2	KNm/rad
Mass moment of inertia, I_v	0.45	0.45	0.45	5.96	6.00	6.04	6.13	6.18	6.24	6.42	22.9	23.9	25.4	27.2	$\times 10^{-6}$ kg·m ²
Max measurable load limit	250 (of rated torque)														%
Static safe load breaking	400 (of rated torque)														%
Shaft weight, approx	0.03	0.03	0.03	0.14	0.14	0.14	0.14	0.15	0.15	0.15	0.36	0.37	0.40	0.41	kg
Transducer with shaft weight, approx	0.7	0.7	0.7	0.8	0.8	0.8	0.8	0.8	0.8	0.8	1.0	1.0	1.1	1.1	kg

Data parameters measured at +20°C
 Sensor Technology Ltd reserves the right to change specification and dimensions without notice.

SGR510/511/512 Torque Transducers

Dimensions (101Nm to 500Nm)

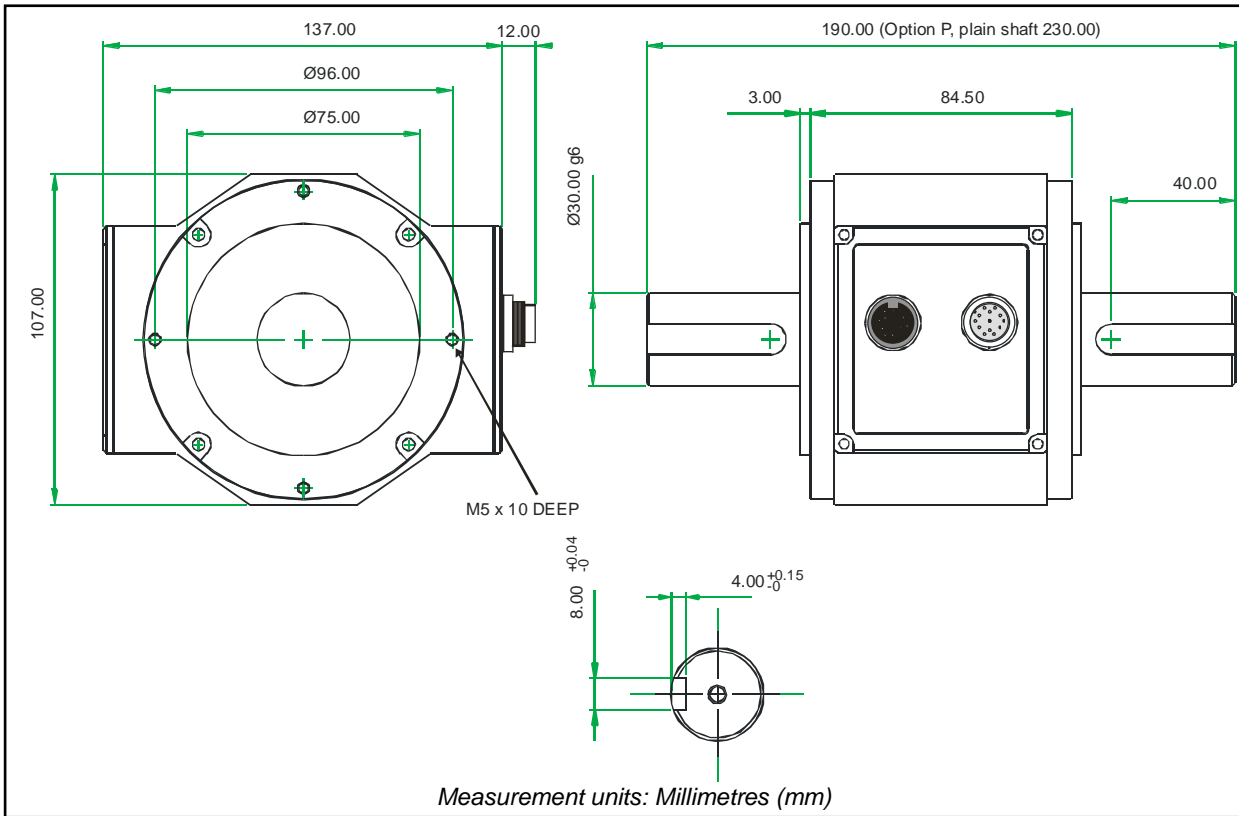

Parameter	Data					Units
Mechanical Properties						
Torque (Max)	175	225	265	350	500	Nm
Shaft Code	FA	FB	FC	FD	FE	
Standard Shaft Type	Keyed					
Shaft Size (Diameter)	30					mm
Torsional stiffness	32.9	35.6	37.2	37.9	39.8	kNm/rad
Mass moment of inertia	138.9	143.1	147.7	151.9	174.2	$\times 10^{-6}$ kg m ²
Max measurable load limit	250 (of rated torque)					%
Static safe load breaking	400 (of rated torque)					%
Shaft weight, approx	1.1	1.1	1.1	1.2	1.2	kg
Transducer with shaft weight, approx	2.4	2.4	2.4	2.5	2.5	kg

Data parameters measured at +20°C
 Sensor Technology Ltd reserves the right to change specification and dimensions without notice.

SGR510/511/512 Torque Transducers

Dimensions (501Nm to 13000Nm)

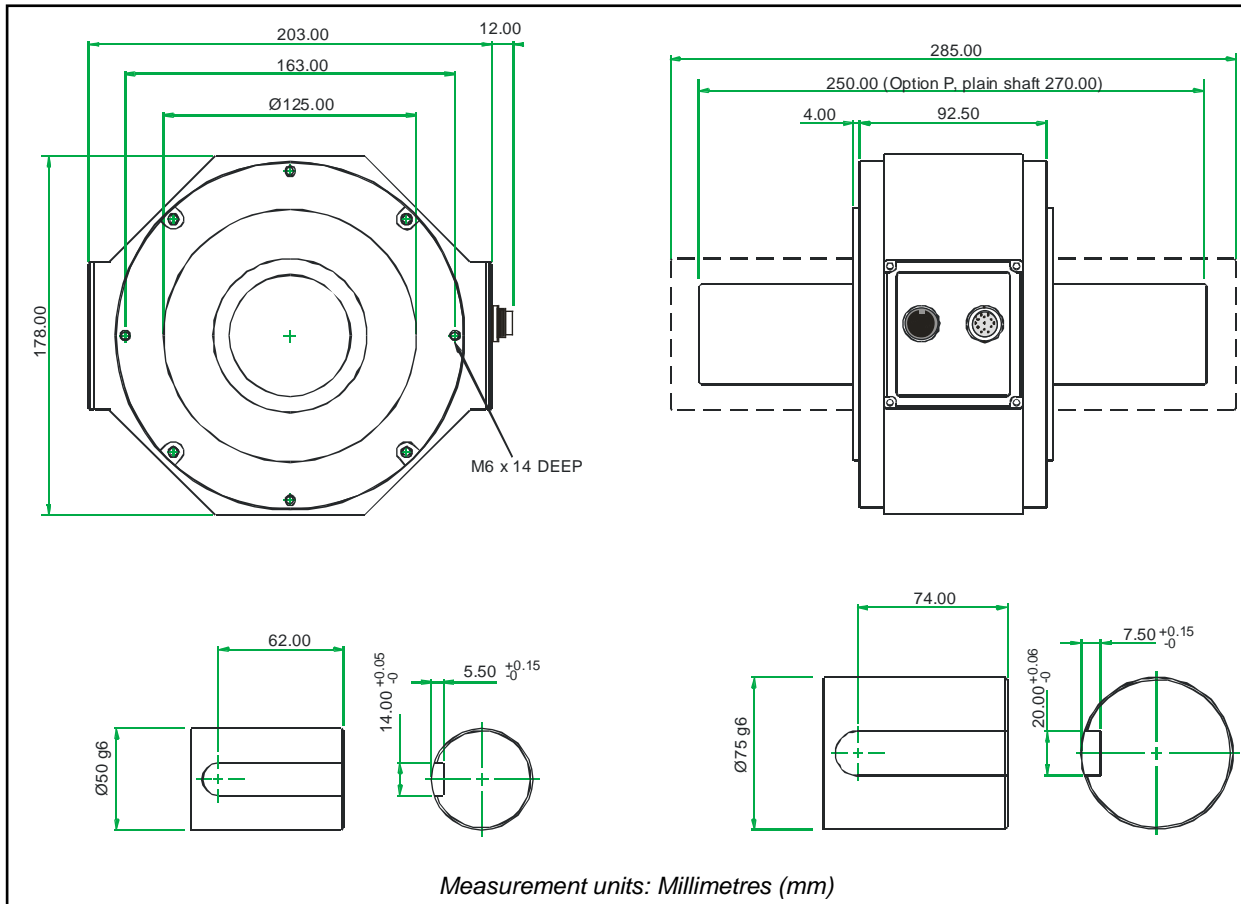

Parameter	Data												Units
Mechanical Properties													
Torque (Max)	650	850	1100	1350	2000	3000	4000	6000	7000	8000	10000	13000	Nm
Shaft Code	GE	GA	GB	GC	GD	HA	HB	HC	HD	HE	HF	HG	
Standard Shaft Type	Keyed												
Shaft Size (Diameter)	50					75							mm
Torsional Stiffness	TBC	TBC	199.2	TBC	214.1	TBC	TBC	914.4	TBC	TBC	945.5	TBC	kNm/rad
Mass moment of inertia	TBC	TBC	1330	TBC	1497	TBC	TBC	7932.7	TBC	TBC	9407.1	TBC	$\times 10^{-6}$ kg·m ²
Max measurable load limit	250 (of rated torque)												%
Static safe load breaking	400 (of rated torque)												%
Shaft weight, approx	TBC	TBC	3.9	TBC	4.1	TBC	TBC	10.2	TBC	TBC	10.6	11.2	kg
Transducer with shaft weight, approx	TBC	TBC	7.1	TBC	7.3	TBC	TBC	13.4	TBC	TBC	13.8	14.4	kg

Data parameters measured at +20°C
 Sensor Technology Ltd reserves the right to change specification and dimensions without notice.

SGR510/511/512 Torque Transducers - Standard Range

● – Standard feature ◇ – Optional feature

	SGR510/511/512	Option Code	Remarks/Purpose
Torque, Speed, Power Outputs			
Torque only	510		
Torque, Speed & Power (60 pulses/rev)	511		<i>User to specify RPM/FSD when ordering</i>
Torque, Speed & Power (360 pulses/rev)	512		
Standard features			
Keyed Shaft Ends	●	K	<i>1Nm will have flats</i>
Voltage output $\pm 5v$ FSD (Fixed)	●	B	
Self Diagnostics	●		
Deep grooved shielded bearings with oil lubrication	●		
Ingress Protection (IP) 54	●		
Optional features			
Plain Shaft Ends	◇	P	<i>Shaft length will be longer than keyed end shafts – consult factory for length</i>
Splined Shaft Ends	◇	T	<i>Consult factory for details</i>
Voltage output $\pm 1v$ FSD (Fixed)	◇	A	<i>In place of Option B</i>
Voltage output $\pm 10v$ FSD (Fixed)	◇	C	<i>In place of Option B</i>
Customer Specified Voltage Output (Fixed)	◇	U	<i>In place of Option B. User to specify range/scale when ordering</i>
Current output 0-20mA (Fixed)	◇	D	<i>In place of Voltage output options</i>
Current output 4-20mA (Fixed)	◇	E	<i>In place of Voltage output options</i>
Current output $12\pm 8mA$ (Fixed)	◇	V	<i>In place of Voltage output options</i>
High Speed Bearings <i>(See Note 9 below)</i>	◇	J	<i>Consult factory for maximum speed allowance.</i>
Sealed Bearings	◇	S	
Ingress Protection (IP) 65 <i>(See Note 10 below)</i>	◇	L	

SGR510/511/512 Series Torque Transducers – Connector and Lead Options

	SGR510/511/512	Option Code	Remarks/Purpose
Connectors & Leads			
Analog Connector <i>12 Pin Lumberg (female)</i>	◇	ACC 1	<i>For user to self wire</i>
Analog Lead (Length 2.5m) <i>12 Pin Lumberg (female) to 15 way 'D' type connector (female)</i>	◇	ACC 3	<i>For connecting SGR to user's system via 15 pin 'D' connector</i>

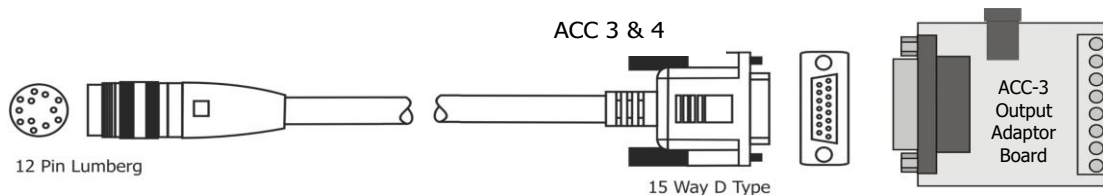

SGR510/511/512 Series Torque Transducers – Additional related products

	Code	Remarks/Purpose
Transducer Display ETD	ETD	<i>Display readout</i>
AC Mains Adapter Power Supply	PSU 1	<i>For providing 12-32Vdc</i>
Transducer Signal Breakout Unit	SBU 1	

Data parameters measured at +20°C

Sensor Technology Ltd reserves the right to change specification and dimensions without notice.

When ordering a Torque Transducer please note that any torque/FSD is possible between ranges – please specify rated torque and options using the following format:

For example: SGR	511 - 15Nm -	K-CL	A 'basic' transducer with torque and speed outputs, rated and calibrated to 15Nm FSD with keyed ends, ±10v and IP65 protection.
Your transducer requirement: SGR			
Max speed (if applicable)		RPM	
Connector or Lead options			
Additional related products			

Glossary of terms and definitions used in this datasheet

- **Accuracy** – The degree of conformity of a measured or calculated quantity, which will show the same or similar results. Accuracy of the overall TorqSense system is limited by the combined error of several factors such as linearity, hysteresis, temperature drifts and other parameters affecting measurements. If errors in the system are known or can be estimated, an overall error or uncertainty of measurement can be calculated.
- **Digital averaging** – The application of algorithms to reduce white noise. In any electronic system, electronic white noise is mixed with the signal and this noise usually limits the accuracy. To reduce the influence of white noise and increase the accuracy of the system different averaging algorithms can be applied. In the TorqSense system a flying digital averaging technique is applied to reduce the white noise commensurate with the level of accuracy required. However, as any averaging algorithm works as a low pass filter, the more averaging that is applied the lower the frequency response. Therefore, each Torqsense system should be optimised to the customer's requirements by choosing the right combination of accuracy/frequency response. Please see relevant part of the Datasheet and User Manual.

Note 1: Any torque/FSD is possible between ranges – please specify max rated torque.

Note 2: Max rated torque should not be exceeded.

Note 3: Please consult factory for applications requiring rotational speeds that exceed maximum figures given. Transducers fitted for IP65 will have running speeds considerably reduced, increased drag torque and accuracy can be affected.

Note 4: SM – Static Mode. Dynamic values will depend upon user application and has to be adjusted accordingly.

Note 5: Digital averaging can be configured by user to optimise accuracy/frequency response for specific user applications. Digital averaging default setting is N=16. For details see User Manual.

Note 6: 4kHz approximate sample rate, actual rate may be slightly under.

Note 7: Output rate figures were calculated from the time taken to capture 100,000 torque readings. Testing was conducted with each connection method configured at its maximum baud rate. Each connection method was tested in isolation on an Intel 7th generation i7 PC running Windows 10. The CAN bus, RS232 and USB interfaces were tested using a stripped-down capture program, while Ethernet was tested via the DLL.

USB - USB is a host-based bus architecture, because of this the output rate achievable may be affected by other bus traffic and host activity.

CAN Bus – CAN Bus is a shared bus technology, where other bus traffic may affect the maximum output rate achievable.

Ethernet – Ethernet carries a much greater overhead than the other connection methods. Ethernet can be affected by dropped packets and other network traffic.

The digital output rate does not in any way influence the internal sampling rate of the transducer. The internal sampling and digital interfaces run asynchronously; the digital interface merely copies data from a buffer at the requested rate.

Note 8: 3 x analog channels are available.

Default assignments for an SGR510 (torque only) are Channel 0 – torque, Channel 1 – torque peak, Channel 2 – torque auto reset.

Default assignments for an SGR51x (torque and speed) are Channel 0 – torque auto (torque/torque peak, switched by peak input), Channel 1 – speed, Channel 2 – power.

Voltage/Current scaling set per option selection, or via Transducer Control on advanced models.

Note 9: At very high speeds, for better balance the factory recommends plain or splined shafts.

Note 10: Transducers fitted for IP65 will have running speeds considerably reduced, increased drag torque and accuracy can be affected.

Note 11: The RPM reading update rate is directly related to the square wave frequency produced from a shaft mounted grating passing through an opto switch. The values specified are based on a standard 60-line grating, for models fitted with an angle encoder or different grating size, replace the RPM with the square frequency in Hz. The square wave frequency can be calculated by this formula: $SQWaveFrequencyHz = (RPM / 60) \times GratingSize$ (for quadrature-based encoders, double the grating size).