

TORQSENSE[®]

SGR570 Series PTO Torque Transducer

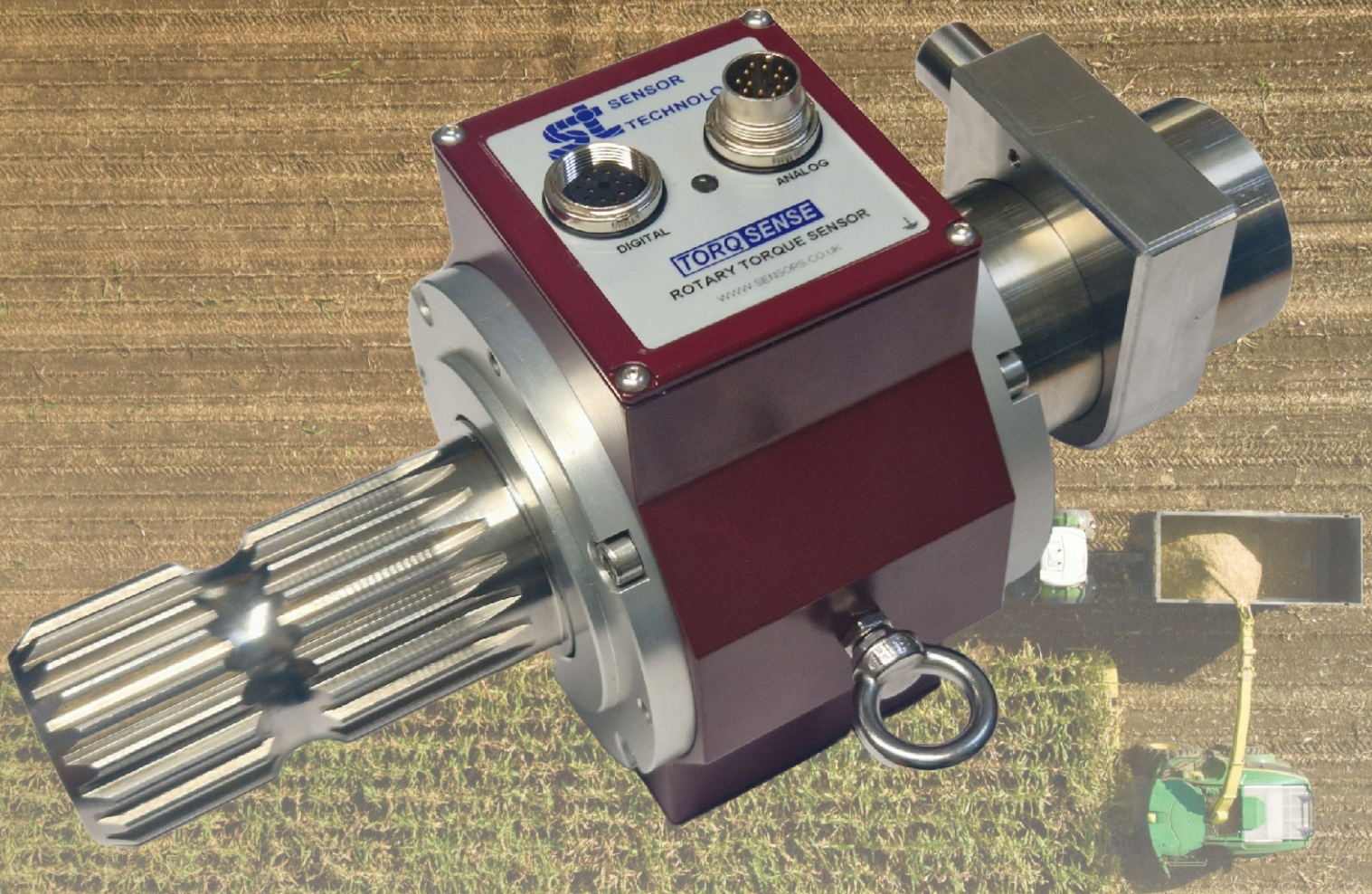

 **SENSOR
TECHNOLOGY**

Tel: +44 (0)1869 238400
Email: info@sensors.co.uk
Web: www.sensors.co.uk

PTO Torque Transducer

Torqsense Digital rotary strain gauge series (SGR) Transducers use non contact technology eliminating the need for noisy slip rings. They are suitable for torque measuring, testing, feedback control of drive mechanisms and process control applications.

The SGR series transducers use modern strain gauge signal conditioning techniques to provide a high bandwidth low cost torque measuring solution with high overrange and overload capabilities.

Benefits & Features

- Transducers up to 2000Nm
- Large fully functional overrange capability of 250%
- Minimal side and end load errors
- Low linearity deviation of $\pm 0.05\%$ FSD
- Low hysteresis error of $\pm 0.05\%$ FSD
- Zero variation in torque signal with rotation (cyclic variation)
- Non contact signal transmission, no slip rings to wear out
- High digital sample rate of 4000 samples per second
- Adjustable torque data smoothness, low pass filter
- Speed measurement / Power computation
- Wide power supply range 12-32 VDC
- Compatible with ethernet gateway module

Technology

The SGR series torque transducers use a full four element strain gauge bridge to measure the torsion present on a shaft. The full bridge helps to diminish errors from any off-axis forces that are sometimes unintentionally applied to the transducer in some test setups. The full bridge also increases the sensitivity and the temperature performance of strain measurement.

A rotor mounted ultra-miniature microcontroller measures the strain gauge bridge and transfers the information back to the stator digitally eliminating any noise pickup usually associated with slip ring and other analog methods of transferring torque data from rotor to stator. External noise pickup into the gauge wiring is virtually eliminated due to the short distance between the strain gauge elements and the rotors measuring circuits.

A multipoint calibration method reduces any linearity errors within the sensor. A large functional overrange capability allows the peaks of a torque signal to be captured more faithfully without any clipping when operating the sensor close to its full scale rating.

All this combined with a mechanical overload capability of over 400% make the SGR series torque sensors a very robust and accurate torque measuring solution.

PTO transducers offer:

- Compatible with all PTO spline types
- Accurate measurement of torque and speed for testing equipment that use the PTO shafts.
- Power calculation
- Simple installation
- IP 65 for robust application where environmental issues may be a problem.
- Transducer configuration software to allow user to change transducer variables
- Connect straight to a PC for data viewing and logging
- Anti rotation eye hook, to stop transducer spinning around with the shaft.
- User configurable limits outputs.
- Wide range input voltage 11V - 32V
- Analog and digital outputs available
- Contactless measurement system (not slip ring)
- Temperature monitoring

TORQVIEW Software

TorqView is an easy to use advanced torque monitoring software, available to assist data recording and instrumentation displays that interface with Windows based PCs.

Features include: 3 types of display, text files compatible with Matlab and Excel and Real time chart plotting. See TorqView datasheet for more details.



LabView VI's are available for users to design their own process control applications. DLLs are also available for users to write their own custom software. Get data from across your network using the ethernet module.

PTO Torque Transducers - Data Specification

Parameter	Condition	Data	Units
PTO Torque measurement system			
Measurement method		Full bridge strain gauge	
Torque range	(Notes 1 & 2)	Up to 2000Nm	Nm
Shaft type		Male 1 3/8" 6 spline to female 1 3/8" 6 spline ISO500-3 Type 1	
Specifications			
Combined non-linearity and hysteresis		±0.1	%FS
Resolution		0.01	%FS
Repeatability		0.05	%FS
Basic Series Transducers ONLY			
Accuracy	20°C, SM (Note 4)	±0.2	%FS
3dB Bandwidth	(Notes 5&6)	250 (default ave. = 16)	Hz
Analog output			
Output voltages (Torque/Speed/Power)		Options available: ±1 / ±5 / ±10 / Unipolar (SGR510 Series default setting is ±5Vdc) (SGR520 Series output voltages are user selectable)	Vdc
Load impedance		Maximum 1	KΩ
Output currents (Torque/Speed/Power)		Options available: 4-20 / 0-20 / 12±8 (SGR520 Series output currents are user selectable)	mA
4-20mA Loop resistance		Should not exceed 400	Ω
Advanced Series Transducers ONLY			
Accuracy	20°C, SM (Note 4)	±0.1	%FS
Digital averaging	(Note 5)	2 4 8 16 32 64 128 256	N
Noise Floor	20°C, SM (Note 4)	0.06 0.04 0.03 0.02 0.015 0.01 0.01 0.01	%FS
3dB Bandwidth	(Note 6)	2000 1000 500 250 125 62 31 15	Hz
Digital output (Advanced Transducers ONLY)			
Connections		CAN Bus Ethernet RS232 USB	
Configuration		CAN 2.0B, 11bit Message Identifiers IEEE 802.3 10BASE-T, 100BASE-TX Data Bits: 8, Parity: None, Stop Bits:1 USB 2.0 Full-Speed	
Baud Rate(s)		1Mbps, 500Kbps, 250Kbps, 100Kbps 10Mbps, 100Mbps 115200bps, 38400bps, 9600bps 12 Mbps	
Output Rate	(Note 7)	Up to 4 kHz Up to 1.9 kHz Up to 1.1 kHz Up to 4kHz	
Rotation speed/angle of rotation measurement system			
Measurement method		Opto switch through slotted disc	
Direct output signal		Pulse output direct from opto switch (TTL, 5V square wave)	
Accuracy		±1rpm up to 2000rpm	
Rotational speed (max)	(Note 3)	2000	RPM
Digital Processing Techniques Processing modes run simultaneously and can be applied to either analog channel or accessed individually via a digital connection. (Note 11)	Based on a standard 60-line grating.	Processing Method	Update rate for analog and digital outputs
		Mode 1 (Slow Method) Frequency Count	1
		Mode 2 (Fast Method) Period Count	0 RPM 1 > 0 RPM $\frac{\text{RPM}}{\left[\frac{\text{RPM}}{1000} \right]}$
			Hz
			Hz
Temperature			
Measurement method		Shaft mounted platinum temperature sensor	
Temperature accuracy		±1	°C
Reference temperature T _{RT}		20	°C
Compensated range, ΔT ₀		0 to +90	°C
Usable range, ΔT _S		-40 to +90	°C
Temperature		Coefficient of zero 0.002	%
Temperature		Coefficient of span 0.01	%
Power supply			
Nominal voltage, V _S		11 to 32 (max)	V
Current consumption, I _S		250 (max) @ 12 VDC	mA
Power consumption, W _S		3	W
Allowed residual ripple of supply voltage, V _{ripple}		500 (above nominal supply voltage)	mVp-p
Electromagnetic compatibility			
EMC compatibility		EN 61326:2006	

PTO Torque Transducers

Dimensions (0 - 2000Nm) 6 Spline

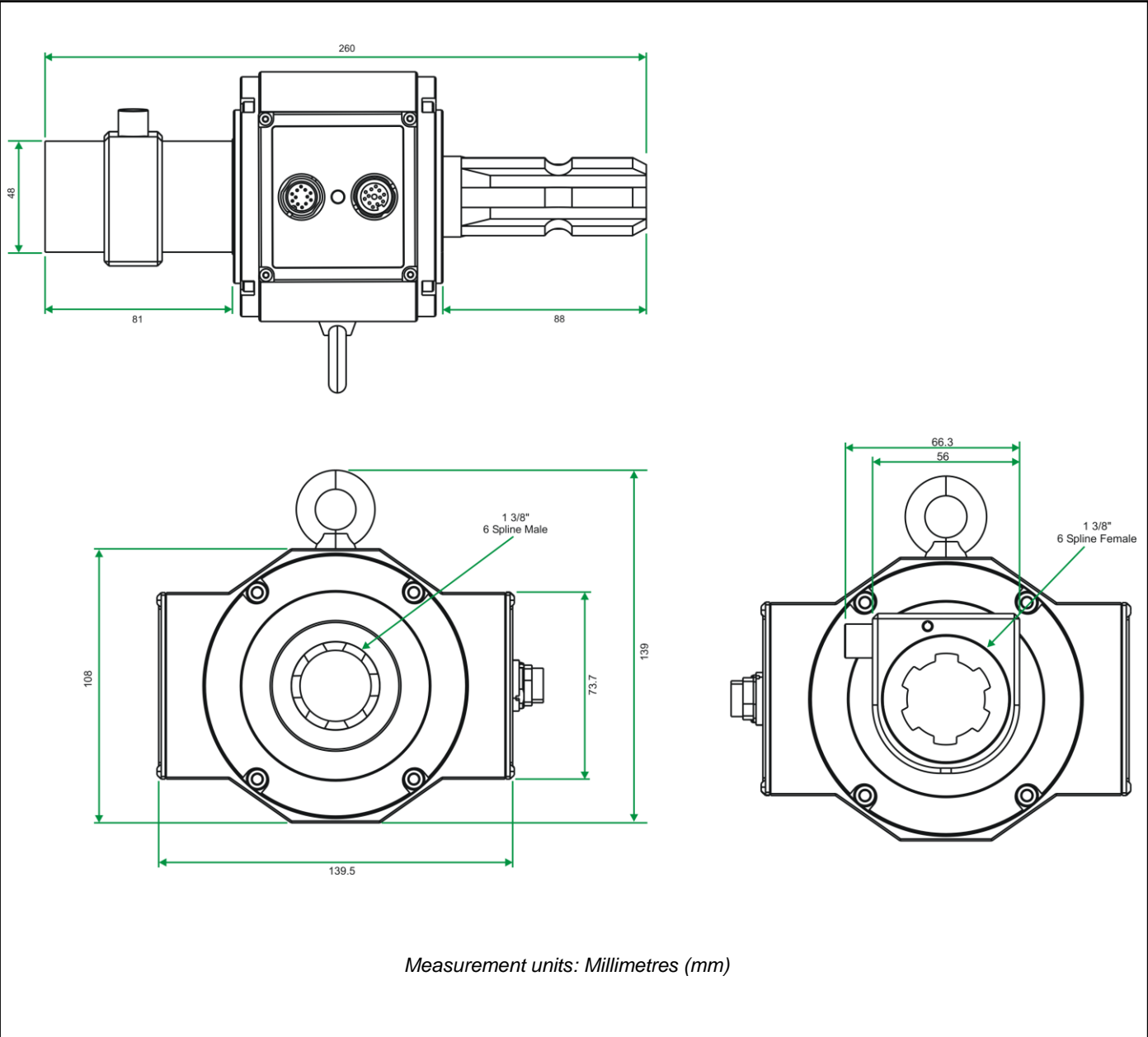

20 & 21 spline available

PTO Torque Transducers – Connector and Lead Options

Connectors & Leads			Option Code	Remarks/Purpose
	Basic	Advanced		
Analog Connector 12 Pin Lumberg (female)	◇	◇	ACC 1	For user to self wire
Digital Connector 12 Pin Lumberg (male)		◇	ACC 2	For user to self wire
Analog Lead (Length 2.5m) 12 Pin Lumberg (female) to 15 way 'D' type connector (female)	◇	◇	ACC 3	For connecting SGR to user's system via 15 pin 'D' connector
Digital Lead (Length 2.5m) 12 Pin Lumberg (male) to 15 way 'D' type connector (male)		◇	ACC 4	For connecting SGR to user's system via 15 pin 'D' connector
Digital Lead Adapter (Length 1m) 15 Way 'D' type (female) to RS232 and Power Connectors		◇	ACC 5	For connecting SGR to PC via RS232 [Also needs Digital Lead (ACC4) to connect to SGR]
Digital Lead Adapter (Length 1m) 15 Way 'D' type (female) to RS232, USB and Power Connectors		◇	ACC 6	For connecting SGR to PC via USB (Option G) or RS232 [Also needs Digital Lead (ACC4) to connect to SGR]
Digital Lead Adapter (Length 1m) 15 Way 'D' type (female) to CANbus and Power Connectors		◇	ACC 8	For connecting SGR to PC via CANbus (Option H) [Also needs Digital Lead (ACC4) to connect to SGR]
Digital Lead Adapter (Length 1m) 15 Way 'D' type (female) to CANbus, USB and Power Connectors		◇	ACC 9	For connecting SGR to PC via USB (Option G) or CANbus (Option H) [Also needs Digital Lead (ACC4) to connect to SGR]

PTO Series Torque Transducers – Additional related products

	Code	Remarks/Purpose
Transducer Display ETD	ETD	Display readout
AC Mains Adapter Power Supply	PSU 1	For providing 12-32Vdc
Transducer Signal Breakout Unit	SBU 1	
TorqView	TV	Torque Monitoring Software

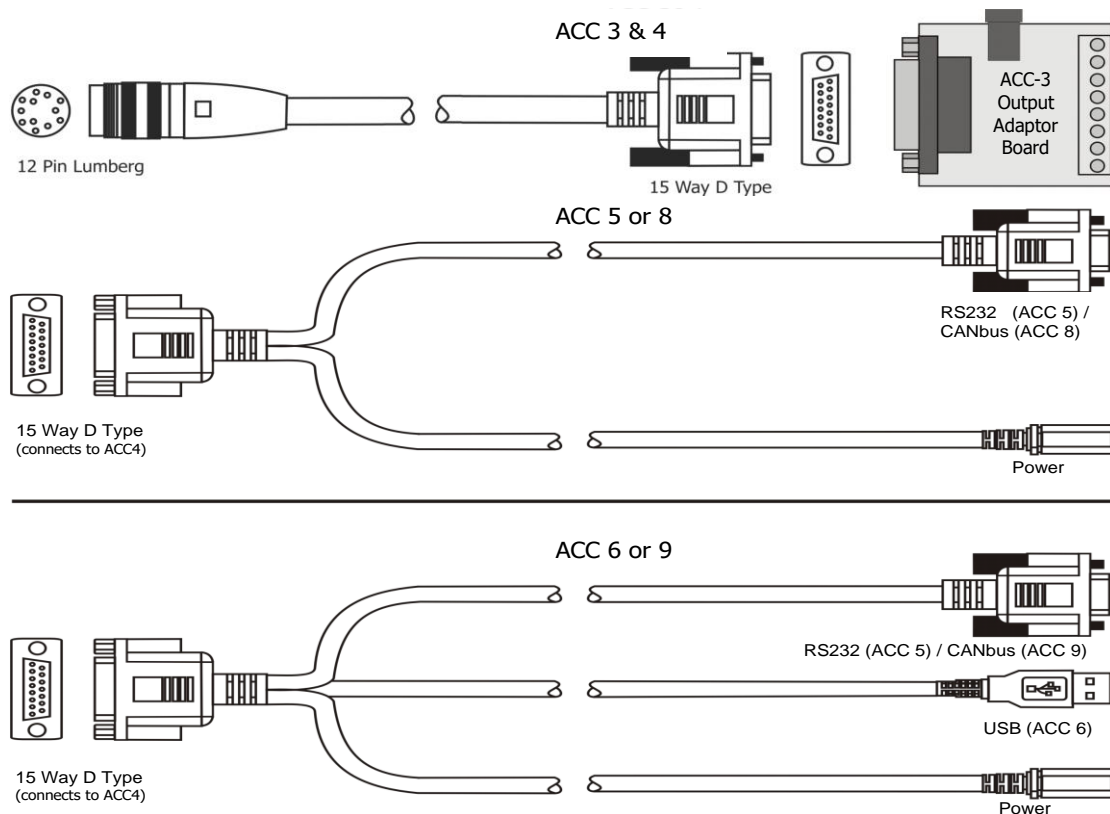

Data parameters measured at +20°C

Sensor Technology Ltd reserves the right to change specification and dimensions without notice.

Glossary of terms and definitions used in this datasheet

- **Accuracy** - The degree of conformity of a measured or calculated quantity, which will show the same or similar results. Accuracy of the overall TorqSense system is limited by the combined error of several factors such as linearity, hysteresis, temperature drifts and other parameters affecting measurements. If errors in the system are known or can be estimated, an overall error or uncertainty of measurement can be calculated.
- **Digital averaging** – The application of algorithms to reduce white noise. In any electronic system, electronic white noise is mixed with the signal and this noise usually limits the accuracy. To reduce the influence of white noise and increase the accuracy of the system different averaging algorithms can be applied. In the TorqSense system a flying digital averaging technique is applied to reduce the white noise commensurate with the level of accuracy required. However, as any averaging algorithm works as a low pass filter, the more averaging that is applied the lower the frequency response. Therefore, each TorqSense system should be optimised to the customer's requirements by choosing the right combination of accuracy/frequency response. Please see relevant part of the Datasheet and User Manual.

Note 1: Any torque/FSD is possible between ranges – please specify max rated torque.

Note 2: Max rated torque should not be exceeded.

Note 3: Please consult factory for applications requiring rotational speeds that exceed maximum figures given. Transducers fitted for IP65 will have running speeds considerably reduced, increased drag torque and accuracy can be affected.

Note 4: SM – Static Mode. Dynamic values will depend upon user application and has to be adjusted accordingly.

Note 5: Digital averaging can be configured by user to optimise accuracy/frequency response for specific user applications. Digital averaging default setting is N=16. For details see User Manual.

Note 6: >5Khz Sample Rate. Up to 10Khz sample rate possible, please consult factory. Digital averaging also affects the analog output, max analog output 3dB Bandwidth = 5Khz when digital average is 1.

Note 7: Output rate figures are calculated from the time taken to capture 10000 torque readings. Testing was conducted with each connection method configured at its maximum baud rate. The maximum output rate available for CAN and USB is dependant on the transducers setup. USB - USB is a host based bus architecture, because of this the output rate achievable will be affected by other bus traffic and host activity. USB has two transfer modes, Single Transfer which requests 1 reading at a time and Bulk Transfer which transfers readings in blocks of 50 Torque/Speed pairs. CAN Bus - to achieve a Torque reading output rate of 10KHz, the Speed reading output rate must be reduced to 100Hz.

Note 8: 2 x analog channels available. Default settings are Channel 1 (voltage/current) – torque. Channel 2 (voltage/current) – speed or power, if ordered.

Note 9: At very high speeds, for better balance the factory recommend plain or splined shafts.

Note 10: Transducers fitted for IP65 will have running speeds considerably reduced, increased drag torque and accuracy can be affected.

Data parameters measured at +20°C

Sensor Technology Ltd reserves the right to change specification and dimensions without notice.